







MODEL C-300	MODEL C-300-RC	
 C-300-S-1XX 2 OPEN SLOTS	 C-300-S-1XX-RC 1 OPEN SLOT	 C-300-S-1XX-RC-3S 3 OPEN SLOTS
 C-300-S-4XX 2 CLOSED SLOTS	 C-300-S-4XX-RC 1 CLOSED SLOT	 C-300-S-4XX-RC-3S 3 CLOSED SLOTS
 RECOMMENDED MOUNTING FOR 2-SLOT STYLE (C-300)	 RECOMMENDED MOUNTING FOR 1-SLOT/3-SLOT STYLE (C-300-RC)	



**NOTE:**  
 INTERMEDIATE SECTION MUST BE  
 INSERTED INTO THE STATIONARY SECTION  
 BEFORE THE END BRACKET IS ATTACHED  
 CHASSIS TRAK IDENTIFICATION LABEL  
 LOCATED ON THE BACK SIDE OF  
 STATIONARY SECTION

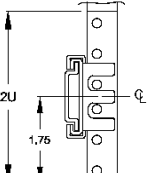
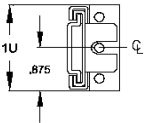
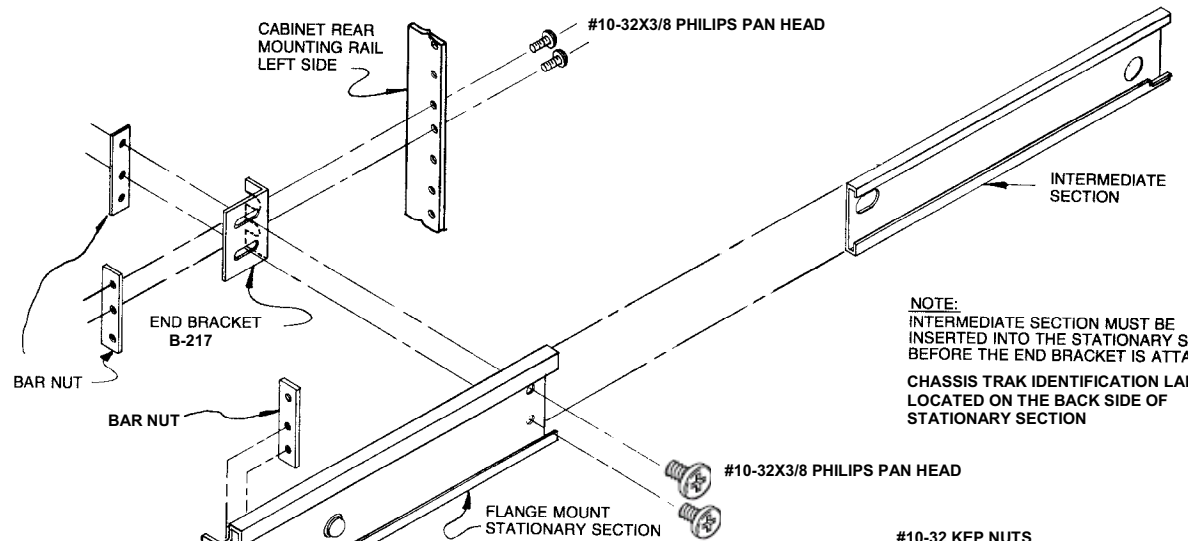
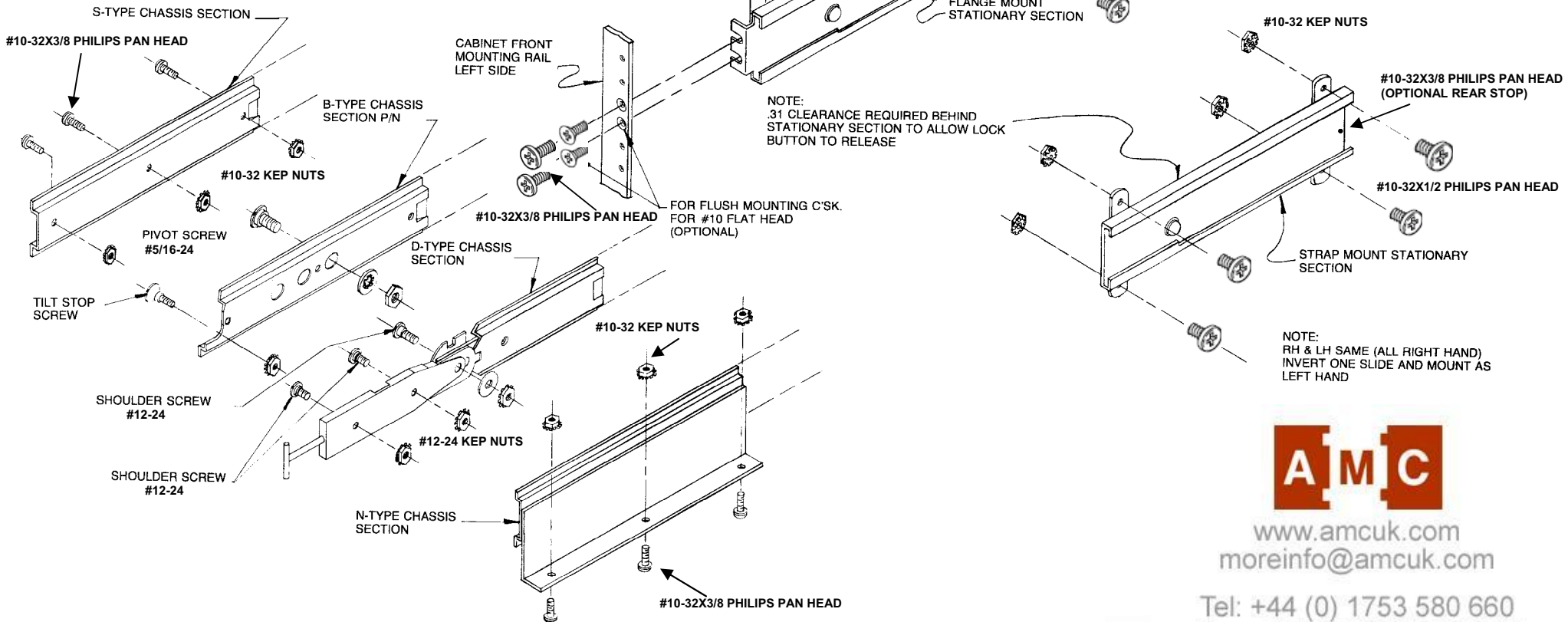

www.amcuk.com  
 moreinfo@amcuk.com

Tel: +44 (0) 1753 580 660  
 Fax: +44 (0) 1753 580 653